

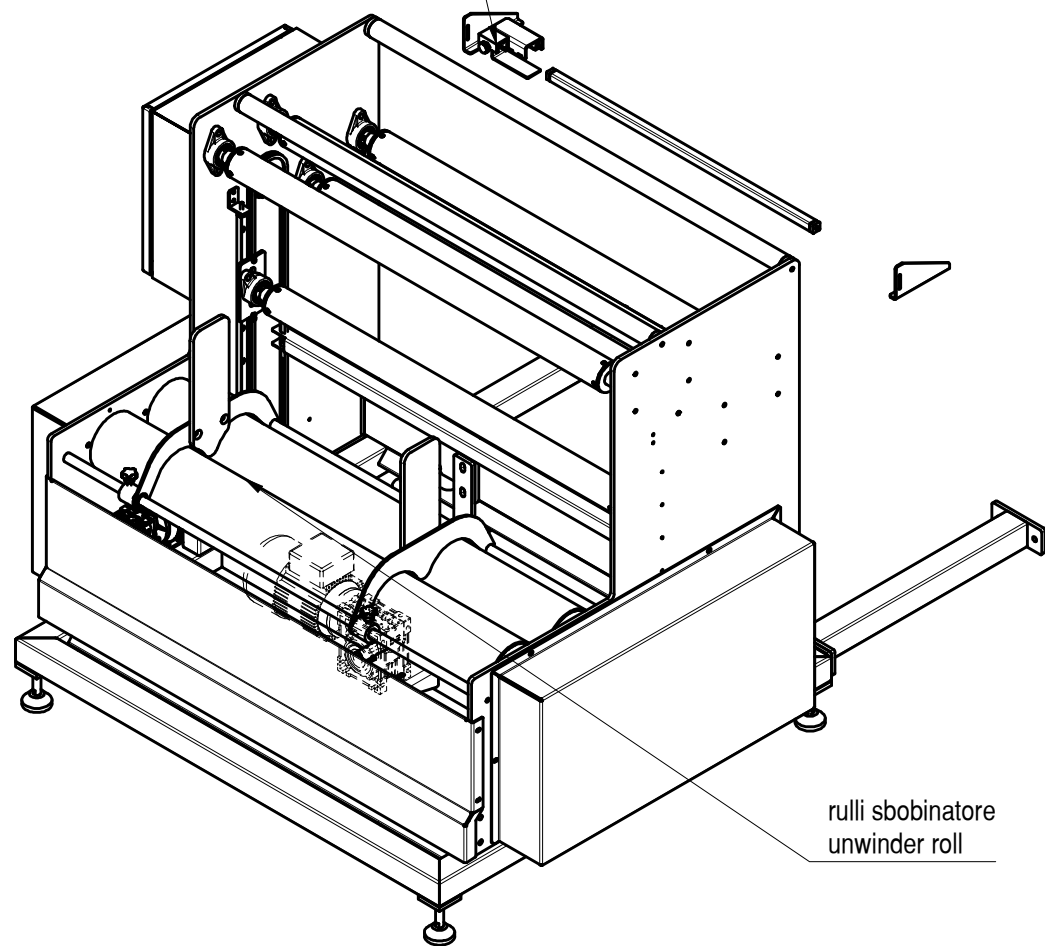

focellula lettura tessuto  
focell reading textile

motore movimento dx/sx  
left ro right movuement engine

motore rulli  
roll engine

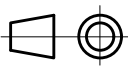

rulli sbobinatore  
unwinder roll

REV.	DESCRIZIONE REVISIONE			DATA REV.	DIS.REV
DENOMINAZIONE: INTRODUZIONE ALLINEATORE				MATERIALE:	
 s.r.l. <b>MACCHINE SERIGRAFICHE</b> 43036 Fidenza (Parma) Italy - Via Bologna, 38 WEB WWW.TEKIND.IT E-MAIL TEKIND@TEK-IND.IT		TOLLERANZE GENERALI ALBERO h11 - FORO H11 ANGOLI: ± 0,25°	SCALA 1:12	DATA 05/11/2021	TRATTAM. TERMICO
		da 1 a 18 ± 0.10 da 19 a 120 ± 0.20 da 121 a 360 ± 0.30 da 361 a 520 ± 0.40 da 521 a 1000 ± 0.50 oltre 1000 ± 0.75		DISEGN. P.M.	TRATTAM. SUPERFICIALE
		PESO	CONTROLL.	NUM. DIS: <b>OM-14015</b>	REV.